

INTERNAL THREADING

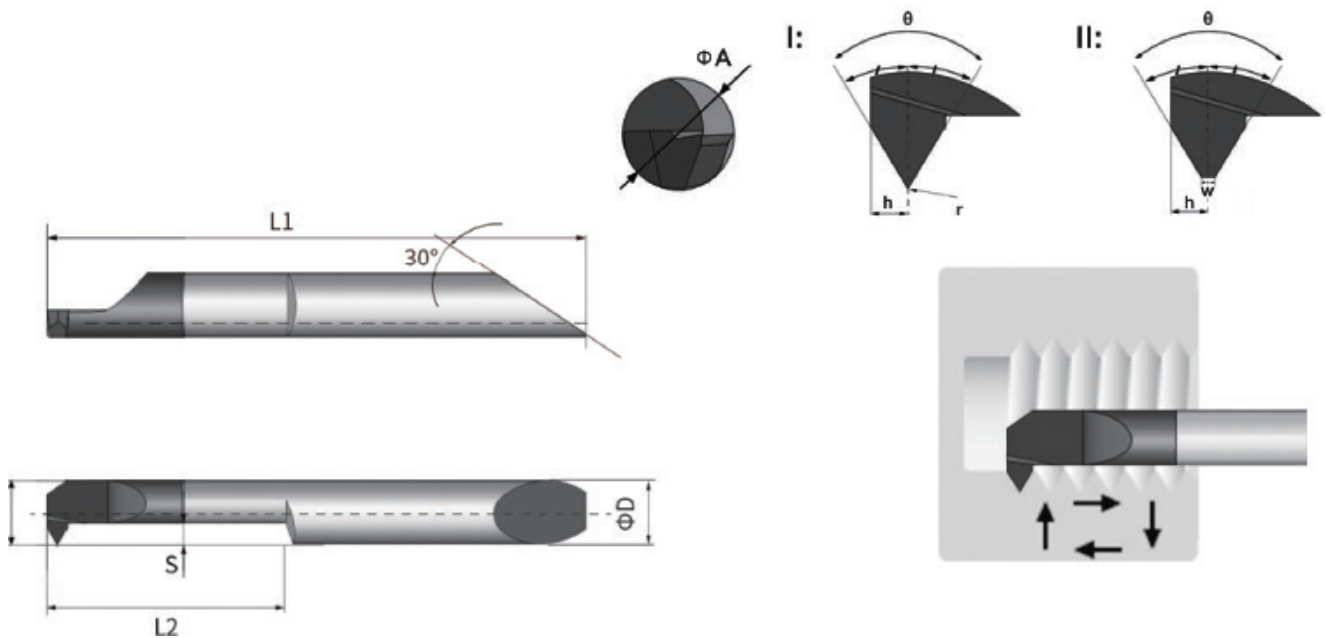

60°

Part NO	Min.Dia (mm)ΦA	ΦD	w	r	h	L1	L2	F	S	θ	Pitch Range (mm)	Type
ESTR1.5-0404A60D	1.5	4	0.03	/	0.25	29	4	1.4	0.4	60°	P0.25~P0.4	II
ESTR2.0-0604A60D	2	4	0.04	/	0.305	31	6	1.9	0.5	60°	P0.3~P0.5	II
ESTR2.5-0804A60D	2.5	4	0.06	/	0.375	33	8	2.4	0.6	60°	P0.4~P0.6	II
ESTR3.0-1004A60D	3	4	/	0.05	0.605	35	10	2.9	1.0	60°	P0.5~P0.8	I
ESTR4.1-1204A60XD	4.1	4	/	0.05	0.72	37	12	3.9	1.2	60°	P0.5~P1.0	I
ESTR4.1-1204A60D	4.1	4	/	0.1	0.75	37	12	3.9	1.2	60°	P1.0~P1.5	I
ESTR5.1-1505A60XD	5.1	5	/	0.05	0.895	40	15	4.9	1.5	60°	P0.5~P1.0	I
ESTR5.1-1505A60D	5.1	5	/	0.1	0.925	40	15	4.9	1.5	60°	P1.0~P1.5	I
ESTR6.1-2006A60XD	6.1	6	/	0.05	1.07	45	20	5.9	1.8	60°	P0.5~P1.0	I
ESTR6.1-2006A60D	6.1	6	/	0.1	1.095	45	20	5.9	1.8	60°	P1.0~P1.75	I